

Ingeniería

Revista de la Universidad de Costa Rica
Enero/Junio 1997 VOLUMEN 7 N° 1

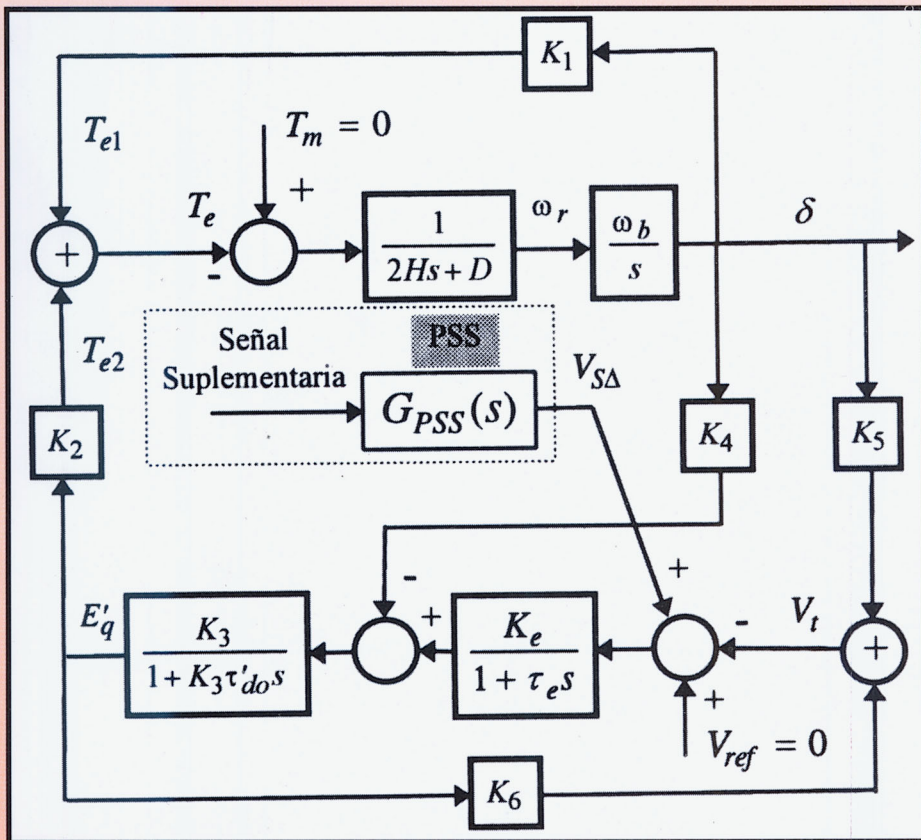

ISSN 1409-2441

INGENIERIA

Revista Semestral de la Universidad de Costa Rica
Volumen 7, Enero/Junio 1997 Número 1

DIRECTOR

Rodolfo Herrera J.

CONSEJO EDITORIAL

Víctor Hugo Chacón P.

Ismael Mazón G.

Domingo Riggioni C.

CORRESPONDENCIA Y SUSCRIPCIONES

Editorial de la Universidad de Costa Rica
Apartado Postal 75
2060 Ciudad Universitaria Rodrigo Facio
San José, Costa Rica

CANJES

Universidad de Costa Rica
Sistema de Bibliotecas, Documentación e Información
Unidad de Selección y Adquisiciones-CANJE
Ciudad Universitaria Rodrigo Facio
San José, Costa Rica

Suscripción anual:

Costa Rica: ₡ 1 000,00

Otros países: US \$ 25,00

Número suelto:

Costa Rica: ₡ 750,00

Otros países: \$ 15,00



Edición aprobada por la Comisión Editorial de la Universidad de Costa Rica
© 1998 EDITORIAL DE LA UNIVERSIDAD DE COSTA RICA
Todos los derechos reservados conforme a la ley
Ciudad Universitaria Rodrigo Facio
San José, Costa Rica.

Revisión Filológica: *Lorena Rodríguez*

Diseño Gráfico, Diagramación y Control de Calidad:
Sergio Aguilar Mora

*Impreso en la Oficina de Publicaciones
de la Universidad de Costa Rica*

Revista
620.005
I-46i

Ingeniería / Universidad de Costa Rica. —
Vol. I, no. 1 (ene./jun. 1991)— . — San José, C. R. : Editorial de
la Universidad de Costa Rica, 1991— (Oficina de Publicaciones de la
Universidad de Costa Rica)
v. : il

ISSN 1409-2441

Semestral.

1. Ingeniería - Publicaciones periódicas.

CCC/BUCR—250



TRENDS IN MACHINE TOOLS RETROFITTING; A SURVEY

Eng. Luis Arturo Rapso, M. Sc.¹

RESUMEN

El presente trabajo tiene como objetivo presentar un estudio amplio de los diferentes aspectos en los que se puede mejorar el desempeño de las máquinas-herramienta (M-H), dando énfasis a las aplicaciones basadas en Control Numérico.

Son estudiados los diferentes conjuntos funcionales que componen la máquina y se proponen los cambios más adecuados a ser adoptados a fin de mejorar la precisión y respuesta dinámica de cada uno de ellos. Además son presentadas algunas alternativas de automatización de M-H a fin de incrementar su productividad dentro de los procesos en que éstas participan. Finalmente se presenta una estrategia a seguir para efectuar procesos de modernización tecnológica (Retrofitting) de (M-H).

Con este trabajo se espera presentar a las empresas del sector metalmeccánico, la opción de la automatización de M-H que provee de confiabilidad y flexibilidad a los procesos alcanzando así, óptimos niveles de calidad y competitividad.

SUMMARY

The objective of this work is to show a wide study about the different ways to improve machine tool (MT) performance, focusing on numerical control applications.

The different functional groups of the machine are studied, and adequate changes are proposed in order to improve its precision and dynamical response. Also, some alternatives for machine tool automation are presented in order to increase their productivity. Finally, a general procedure is described for developing retrofitting works.

This work is proposed in order to show how the automation of machine tools can give confiability and flexibility to obtain optimal levels of quality and competitiveness.

1. INTRODUCTION

The accelerated development of micro-electronics in recent decades has been considerably advantageous in the productive process automation; affecting man in relation to the professions, work places and life style.

Industrial automation gives an alternative within the universe of answers to the present market demands, it enables improvement in quality, process and profit. For these reasons a priority is the domain of the technologies related with automation.

The Machine Tool automation has two approaches: the rigid and the flexible approach. To automate MT it is necessary to make some

modifications. This is the theme to be developed in this work.

2. MACHINE TOOL AUTOMATION TYPES

There are some different kinds of machine tool automation as shown by the following.

2.1 AUTOMATIC MACHINES

This kind of MT has been designed to machine only one part or do only one operation within the part or similar parts family. In this application some adjustments are required for machining a large quantity of some kind of parts.

This type of machine works with minimal human supervision, and in some cases it can present some degree of intelligence. An example is within the automobile motor parts industry, where large fabrication lots of the same piece are machined.

2.2 TRADITIONAL MACHINE TOOLS

Hand wheel-manipulated machine tools are widely used in machine shops. There are different aspects to be changed in order to improve their productivity. Several alternatives are exposed as follows.

2.2.1 DIGITAL READOUT:

It is related to the installation of digital measuring systems with digital readouts. It enables the operator to feel confident with the displacement of the machine axis and to obtain a fast execution of the part by eliminating the time required to stop the machine to take measurements during the machining of the part.

2.2.2 POINT TO POINT MOTION CONTROLLERS:

This kind of application introduces an automatic control system that provides the positioning of the part. Actuator and sensor systems are used to develop the movement up to a pre-set position and the trajectory taken to attain this position is neglected. Typical applications of these systems are the drilling machines at machine shops and printed circuit boards.

2.2.3 CONTOURED MOTION CONTROLLERS:

This application is similar to the one described above but in this case the movement is done over an established trajectory. The controller also maintains a constant velocity over the contour machined, and this application is very common in the machining of injection or blow molds. The contoured movements can be 2 or 3 dimensional.

2.2.4 AUTOMATIC MACHINES:

In this case, the consideration is with a traditional MT adapted to machining the same part

as was described above. A programmable logic controller and some actuators and sensors are implemented in the machine to develop the sequence necessary for machining the part.

2.2.5 SADDLE MOUNTED TYPE:

Another alternative recently released to the market is the so called "Saddle Mounted CNC". It is a kind of kit developed to be installed over the bed of a traditional MT as an accessory, but it provides a numerically controlled positioning system that is joined with the machine spindle to conform a CNC machine. In this manner, most of the changes required to convert a traditional machine to numerical controlled operation are avoided.

2.3 NC OR CNC MACHINE TOOLS RETROFITTING

The retrofitting is a modernization of the components of the control system of an NC or CNC MT. It includes the position controller (computerized numerical control (CNC)), servo drives, and measuring systems. The retrofitting concept can be interpreted as a technological recuperation of the machine to get modern functioning, and it gives better characteristics for the operation of the machine as well as new functions. In some cases it is necessary to make profound changes in the machine components, even replacing them with others of modern design. The retrofitting is developed in NC machines whose controllers have become obsolete. On the other hand, it can be considered a conventional machine tool under the following approaches:

2.3.1 BRAND NEW MACHINE TOOLS WITH CNC CONTROLLERS:

Some machine tool builders have introduced the production of CNC machines by adapting their conventional products. These machines can not give the performance expected in machines designed for CNC operation. The technical problems encountered with the adaptation of new machine tools are similar to those encountered with the adaptation of used machines, but the considerations about the machine condition are avoided.

2.3.2 REFORM AND MODIFICATION OF USED CONVENTIONAL MACHINES:

The application of numerical control to conventional machine tools in service comprise different modifications. First of all, it is necessary to improve the mechanical characteristics of the machine to eliminate the play and misalignments, etc. Also, structural modifications, component substitution and reconditioning must be done. It is possible to expect better characteristics of the renovated machine with the new and reconditioned devices included.

2.3.3. RETROFITTING OF NC O CNC USED MACHINE TOOLS:

Besides the introduction of a new controller, for the retrofitting of MT with obsolete controllers, mechanical modifications and new electrical wiring, may be necessary. Most of the time the machines have performed hard jobs, meaning that special attention must be given to different adjustments and adaptations probably necessary to get a successful machine.

3. STUDY OF THE DIFFERENT FUNCTIONAL GROUP COMPONENTS OF THE NUMERICAL CONTROL MACHINE TOOL.

Besides the CNC, the other relevant components of the machine tool which deserve detailed attention, and that are considered as possibilities to be reconditioned, substituted or reformed, are listed and discussed as follows:

- Guides.
- Mechanical Transmission Elements.
 - Screws.
 - Belts.
 - Couplings.
- Servodrives.
 - Feed drive.
 - Spindle drive.
- Position measure systems:
 - Linear.
 - Rotary.
- Control system.

3.1 SLIDE WAY GUIDES

There are two alternatives for worn guides:

- If the machine does not require high dynamical performance, the renovation of the guides may be done by rectifier grinding of the surfaces, or it may be possible to cover the surfaces with anti friction materials as "Turcite B". It is recommended to provide the guides with a centralized lubrication system and adequate guide covers to avoid pollution.

- When the renovation is done on a NC or CNC machine tool where high dynamical performance is required, it is necessary to replace the slide guides by rolling guides.

It is similar in the case of the ball screws, where the "stick slip" is minimized by taking advantage of rolling elements and the following benefits can be expected:

- Less friction.
- Less power consumption.
- Less heat generation and therefore less thermal expansion of the whole machine.
- Simplified lubrication.
- Higher feed velocities.
- Higher precision, etc.

The manufacturer handbooks give all the information necessary for the dimensioning and selection of the adequate elements. The principal parameters concerned are:

- Load capacity (static and dynamical).
- Required speed.
- Lifetime.
- Mounting type.

The roller guides are preferred over ball guides because of the higher load/size ratio, reliability and rigidity [Da Costa]. In the case of high precision requirements (less than one micrometer) the use of aerostatic or hydrostatic guides is recommended.

3.2 MECHANICAL TRANSMISSION ELEMENTS

3.2.1 BALL SCREWS:

Ball screws have the function of transforming rotary movement of the servomotor shaft into linear movement. The precision of the screw is reflected in the precision of the machined part; therefore it is the most important function of this device in a machine tool.

In old machines, the screws are of trapezoidal lead type, therefore, severe wear by the frictional contact between the surfaces is usually observed. Also, the phenomena of "Stick Slip" as was mentioned above, is the origin of low frequency vibration.

The modern solution to the problems mentioned is the substitution of the trapezoidal screws by ball screws because they eliminate almost all of the friction by changing sliding for rolling contact. In this device the play is eliminated by the preload of a two-part nut; one against the other. The change of the trapezoidal screw by a ball screw involves the selection of the bearings on the screw mounting. In the case of old machines with ball screws it is necessary to verify the wear status of the screw, the nut, and the balls. It is recommended to consider the renovation or the substitution of the assembly. Its rigidity can be increased by tightening the screw. The selection of this component is based on the following parameters:

- Precision class, it depends on the use of the component.
- Lead, cinematic characteristics.
- Axial load capacity, it depends on the mounting system.
- Critical rotary velocity.
- Lifetime.
- Torque to be transmitted.

Recently a special kind of nut has appeared on the market for trapezoidal screws. It has an incorporated preload system in order to eliminate the play; the sliding surface in the nut is machined in anti friction material, Turcite B.

3.2.2 TRANSMISSION BELTS:

For the transmission of movement the use of synchronized timing belts is recommended. Besides the synchronization, the belts don't slide and have very good dynamical performance when correctly selected and sized, also the play is eliminated by the fit of the belt teeth and the pulley teeth. [Lichtblau,89]

3.2.3 COUPLINGS:

Other important elements are the couplings, they must be selected to obtain the maximum torsional rigidity with low inertia and play. Special attention to their fixation is recommended. The use of key slots must be avoided; a recommendation is the use of collets to prevent vibration. The servomotor mountings must be done using very rigid flanges.

3.3 DRIVE SYSTEMS

3.3.1 Feed drives:

The adequate dimensioning and selection of the feed drives is a fundamental part in the retrofitting process. It represents a high part of the cost and represents most of the precision capability of the machine.

In a conventional machine there is an intermediate cinematic chain, composed of gears, rack and pinion and trapezoidal screws, that provide the relative movement between the machined part and tool. This approach is very disadvantageous because of the accumulated errors along the chain of elements and their poor dynamical performance.

With the advent of the Computerized Numerical Control (CNC) the error sources should be eliminated because they cause instability of the control system. Servomotors have been developed with high capacity to be commanded and they can be coupled directly to the ball screw or by a timing belt transmission. The principal requirements to be satisfied by the servomotors are the following:

- High positioning precision.
- Velocity homogeneity and constancy.
- Low inertia.

- High dynamical response without overshoot.
- High overload capacity.
- Fast movements and stops with high precision.
- Four quadrants operation.
- Possibility of measurement systems integration to numerical control.
- Velocity regulation within 1:100000 or higher.
- Low maintenance.
- High working lifetime.
- Reduction of the overall dimensions.

There are several possibilities which meet the requirements mentioned, with the principal alternatives being:

- DC servo drives.
- AC servo drives.

The DC servo drives have been used frequently in the past, for NC machine tools, but now they are substituted by modern technologies. Basically the servo drive is composed by two parts:

3.3.1.1 SERVOMOTOR:

The servomotors are very important parts of the positioning system. They perform the function of transforming the electrical energy into mechanical energy, also they transform the data of the positioning program into movement, velocity and torque.

The servomotor is distinguished from a common DC motor because the servomotor is designed to reach an optimum dynamical performance, whereas the common motor is designed to minimize its costs and optimize the efficiency. Servomotors respond rapidly and with precision to a command; they can be classified as follows [Lichtblau, 89]:

By the movement type:

- Rotary servomotors.
- Linear servomotors
(with translative movements).

By the continuity of the movement:

- Continuous movement servomotors.
- Discontinuous movement servomotors
(step motors).

By the feed energy form:

- Direct current servomotors (DC).
- Alternative current servomotors
(CA, synchronous or asynchronous).

The most adequate servomotor for every case must be selected in order to obtain the best dynamical response for the system. The latest tendency in the field of CNC machine tools is the use of DC brushless servomotors as well as the use of AC servomotors. The fact is that these motors have good dynamical characteristics, have compact size and have a long lifetime with low electric noise generation. Another advantage of this kind of servomotors is the better capacity for heat evacuation from the coils because they are in the stator. This means that they can operate under higher current densities and peak currents.

3.3.1.2 DRIVERS:

The power electronics must be adequately selected in association with the servomotor drive, because the servomotor and driver make a system with complementary characteristics. There is a marked tendency to use Pulse Width Modulation inverters (PWM), associated with different control strategies to feed the servomotors mentioned above.

3.3.2 SPINDLE DRIVE:

In reference to the spindle drive a recent possibility is the use of induction servomotors with field oriented controllers. They exhibit the possibility to control the angular position of the spindle as another controlled axis and the machine earns a high versatility [Erickson, 89]. Another alternative is the use of high frequency spindles, with these devices it is possible to obtain high material removal rates when machining soft material such as aluminum operating at 40000 rpm and 40 kW. This application has reduced costs by about 70%, compared with a conventional machining process [Holland, 89].

The more conventional alternative for the spindle is the use of DC motors with permanent magnets or with field windings. This kind of motor has limitations for the rotary velocity, power capacity and also requires more mainte-

nance because of the brushes. On the other hand, there is another alternative, this is the use of frequency inverters to control the velocity of AC asynchronous motors (induction) such as the popular "squirrel cage". In this type of motors the velocity is proportional to the voltage frequency. To obtain the regulation, the three phase current line is rectified to DC power, after which, it is converted back to alternate current. An adequate V/Hz rate is maintained to make the torque stable. This is accomplished with a PWM inverter and a control system to provide a three phase output with variable frequency and amplitude [Martin, 90].

3.4 MEASUREMENT SYSTEM

3.4.1 LINEAL MEASUREMENT SYSTEM:

Position measurement can be developed directly or indirectly. When the measurement is accomplished by another related magnitude it is called an indirect measurement. Direct measurement is more adequate because it allows avoiding the error introduced by intermediate magnitudes, and by the related mathematical correlations. The more widely used measurement systems are electro-opticals, based on crystal scales, with lines spaced by 20, 40 or 100 micrometers. The measurement is developed by the incidence of a condensed light beam, a sensor provided with a graduated mask and photoelectric cells. During the movement of the sensor along the scale, the light passing across the marked glass is transformed into electrical pulses, and interpolated by dedicated electronics. Another system used for position measurement is based in the inductive principle (Inductosyn, resolvers, etc.), however these devices are less common in modern applications, because the electro-optical devices have the advantage of giving a digital response that makes easier the processing controller.

3.4.2 ROTARY MEASUREMENT SYSTEMS:

Indirect measurement with rotary systems is only acceptable when the error generated by the lead and the play is less than the maximal error admitted for the machine. In the positioning

systems, rotary encoders are used to develop angular measurements, where the function of the encoders is similar to linear scales, substituting the scale by a graduated disc. When coupled to the servomotor shaft or directly to the ball screw, an encoder enables an indirect displacement measurement. Literature recommends the use of linear scales for lengths under 3 meters and the use of encoders for greater distances associated with LASER calibration and CNC with error compensation [Coleman,90]. Encoders provide direct angle measurement and the codification can be incremental or absolute.

3.5 COMMAND AND CONTROL SYSTEMS

The CNC performs the positioning control in the machine tool. The control systems in the numerical control machines have evolved with time, passing through the following stages.:

- 1954 NC based on valves computer.
- 1960 NC with relay logic technics.
- 1964 transistorized NC.
- 1968 NC based in integrated circuits.
- 1972 NC controlled by minicomputer.
- 1976 NC with microprocessor technology (CNC).
- 1979 Adaptive control.
- 1981 Very large scale integration (VLSI)
- 1990s controllers based on 32 bits microprocessors and DSP (Digital signal processors).

The CNC receives as input the machine parameters and the part program. The first data provide information about the machine characteristics, and the second data has the geometrical and technological information about the part to be machined. The information is entered by one of the following alternatives:

- Keyboard (MDI Manual Data Input).
- Punched tape.
- Floppy disc.
- Supplied by a computer that distributes the work to one or more machines (DNC).

During the execution of the part program, two types of information are decoded: (1) the

geometrical information is processed by the interpolator, to supply the corresponding reference, to the position controllers of each movement axes; (2) the technological information is processed by the logical controller that provides the command signals to the actuators (Tool change, lubrication, coolant system etc.) and receive sensors signals to monitor the process.

Some relevant considerations to be considered for the CNC selection are the following:

- In the selection of a CNC one must take into consideration the advantages of selecting a controller already used in the company in order to standardize the company controllers. The familiarity of the users with the controller is profitable, and reduces training and implementation costs.
- Select the characteristics of the CNC according to the machines possibilities in terms of axes number, tool changer, pallets changer, rotary table, chip remover, automatic lubrication system, etc.
- Other characteristics should be considered such as: processing time, microprocessor type, position compensation, graphics simulation, peripheral interfaces, failure autodiagnosis, etc.

3.5.1 OPEN ARQUITECTURE CONTROLLERS

A recent introduction by different suppliers is the possibility of installing motion controller boards in personal computers to work with a special software; this is the so called, open architecture approach.

The PC based CNC systems offer many advantages, first of all, the price. This is a low cost approach, also the PC platform gives very high flexibility and offers a wide array of well supported choices of software and hardware.

The PC based CNC is easy to customize and expand in accordance with the user demands. Memory can be easily expanded and network facilities can be developed easily.

PC boards began with the appearance of dedicated IC's for motion control, for example the HCTL 1000/1100 from Hewlett Packard, the LM 628/629 from National Semiconductors, the

3701/3702 from Toko [Rapso,95], the TSC X3301, the MC1401 from Performance Motion Devices, the GI-1200 from Galil Motion Control, etc. These devices are designed to work in parallel with a central microprocessor which develops the other functions such as memory access, video control and supply of motion parameters by the PC Bus interface.

More recently, faster DSP's have substituted the motion control IC's in PC based CNC boards, it has reduced the costs and increases the device performance. Some of the features reported by manufacturers of DSP motion control boards are:

- Control of up to 8 axes.
- 16 bit based digital to analog converters.
- PID Position Control algorithm with velocity feedforward.
- Up to 1000 instructions per second in a four axes basis.
- Sampling Frequency of 6 kHz -4 axes.
- Programmable velocity, and acceleration profiles, "on the fly" parameter changes.
- I/O PLC functions on the same board.

Most of these devices enable one to program the system using the common "G" and "M" codes (EIA-274D standard) [Rapso,95].

3.5.2 CIM INTEGRATION

In several recent proposals, for the low cost CIM concept (Computer Integrated Manufacturing), the basis of the hardware implementation is the use of PC's and a host computer for database [Kopacek,95]. This is another reason to apply the open architecture approach to retrofit old machine tools in small and medium size companies as in the Costa Rican case.

There are various protocols and communication standards, all of them easily implemented in PC's, but in the case of commercial CNC controllers it is a CNC supplier prerogative.

4. WORK PLANNING

4.1 MODERNIZATION PROCEDURE PROPOSED:

The following modernization procedure is proposed in order to systematize the actions to modernize (Retrofit) a used machine tool:

- a) Establishment of previous requirements: In this part, some goals are established, for example: Reforms definition, increase or decrease of axes number, adaptation of tool changer system, pallet system changer, changes in the servodrive and spindle technologies, machine resolution, precision and repeatability required, etc.
- b) Candidate analysis: In this part, a evaluation is done on the different machine components function and condition. This is the way to establish the substitution requirements in every machine component.
- c) Needs list: At this stage it is possible to develop a components list to be incorporated or substituted in the machine.
- d) Redesign: In this stage different tasks are developed, which are directed to detailed solution alternatives selected to attain the goals established at the beginning.
 - Information collection.
 - Conception.
 - Dimensioning.
 - Analysis, including technical and financial evaluation.
 - Execution planning.
- e) Execution: This stage includes all the assembly and set up actions required for the implementation of the alternatives selected in the point c.
- f) Dynamical and metrological evaluation: When the retrofiting job is finished, dynamical and metrological evaluation must be done in order to know whether the pre-established requirements were reached or not.
- g) Optimization: This stage include the adjustments necessary to improve the machine characteristics after the evaluation.

- h) Running test: After the machine tests finish, it is time to run the machine under a productive process for an adequate time established according to the machine operation conditions, in this way it is possible to evaluate the effectiveness of the previous procedure. Non satisfactory performance leads to the need to check and change the above stages.

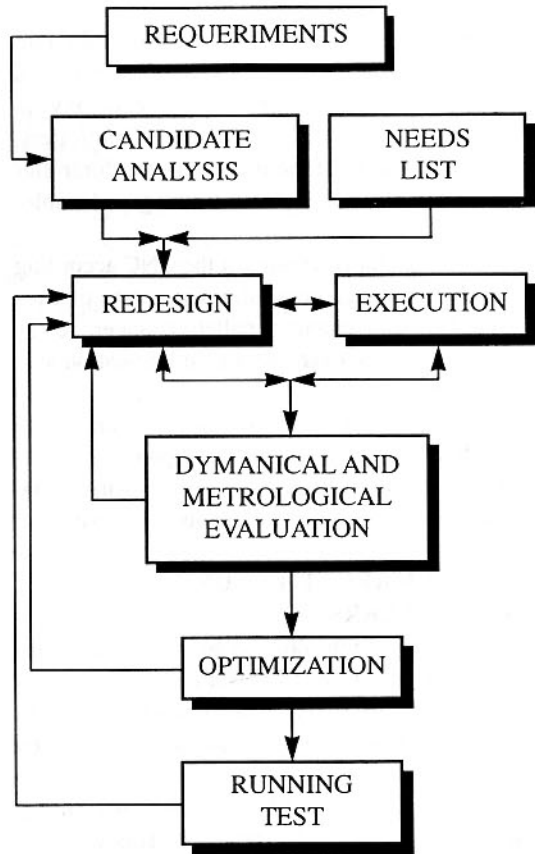

Figure 1 Procedure Proposed

4.2 CONSIDERATIONS ABOUT THE MACHINE TO BE RETROFITTED:

The evaluation of the machine to be modernized is a fundamental part of the work success to obtain a confiable and precise machine. Modern CNC's have the capacity to compensate the play and lead error of the ball screws by using

software, although, it is not possible to expect good results if you start with a machine unable to make parts within an acceptable tolerance band. A study must be done about all the error sources, the quantity and type of wear, vibration levels and causes, misalignment, etc. Only in this way is possible to determine if the machine is technically able to be retrofitted. The literature points out the benefits to be attained with retrofitting compared to new acquisition in delivery time, and initial inversion. When the machine seems obsolete, the following are some recommendations to determine, if it is a good candidate to be retrofitted.

It is hard to know when the machine is a candidate to be retrofitted, although, some european authors recommend to considering old large and heavy NC machines as good candidates. That is because their substitution by new ones is expensive and delivery time is very long, making sense to choose these machines when it is observed that the trend is to decrease the prices of the "on the shelf" small machining centers (less than 7.5 kW). Large rectifiers, turning lathes, vertical turret lathes, boring machines and machining centers can well be considered as candidates for retrofitting. A recommended signal to determine when a retrofitting is necessary is when the "lead time" of the machine is more than 20% and it affects the machine productivity and delivery time of the machined parts.

The more relevant aspects about deciding whether to retrofit or buy a new machine tool are: delivery time, costs, the possibility of selecting some of the machine components and to continue using the machine tooling instead of acquiring new ones, and also the possibility of reducing the adaptation time of the machinists to the new machine. Finally, the modernization of similar machine groups implicates a considerable cost reduction by the repetitiveness of the work.

4.3 ABOUT THE USE OF THIS PROCEDURE:

During 1992-93 two retrofitting jobs were developed. They were carried out in the GRUCON, in the Universidade Federal de Santa

Catarina on a Pratt & Whitney NC milling machine, and a CZPEL turret lathe. The first was under the author's responsibility and the following actions were developed:

- Technical evaluation.
- Numerical controller selection.
- Feed drives and measuring systems selection.
- Design and execution of a jogging panel and electric power panel.
- Design and execution of electronic interfaces.
- Design of the mechanical components for the retrofitting implementation.
- Frequency and time response analysis of the machine.

The dynamical tests developed, demonstrated satisfactory machine performance, showing fast positioning and a damping coefficient value within the literature recommendation. [Rapso,94].

Actually the author is advisor of a graduation project to retrofit a conventional milling machine by incorporating DC servomotors and a PC based Servo Controller (LM628 chip based) and CNC software. It is expected to develop experiments in the following aspects:

- The use of trapezoidal lead screws with Turcite B, anti-backlash nuts associated with the motor rotary encoder as a measurement system, and the use of a linear scale provided with a special adjusting and mounting system to calibrate the positioning errors.
- The use of a linear scale (direct measurement) for the knee positioning control system in order to avoid the error caused by the play of the mechanical components in the cinematic chain.

5. CONCLUSIONS

The principal factor which defines the technical and economical success of retrofitting is the quantity and extension of the modifications made. The substitution of an obsolete controller by a modern one is the more simple way to retrofit a machine. In such a hypothetical case, when

no mechanical changes are necessary, the effectiveness is higher, because modern controllers, which include programmable logical controllers, have the flexibility to be programmed, and can be easily adapted for any machine.

From the economical viewpoint, advantages depend on how old and obsolete the substituted controller is, because new controllers have greater memory capacity and capabilities for trouble shooting and failure detecting.

Acquiring a computer and software for programming obsolete controllers, can be a difficult choice to consider, when compared with the retrofitting option. Modern CNC's simplify the operation and programming and also compensate the machine errors.

Numerically Controlled (NC) Machine Tools have been widely used in mechanical manufacturing processes in order to improve accuracy and productivity. Traditional machine tools have been gradually discarded. Although some of them are not so useless to become obsolete. In developing countries, like Costa Rica, most of the machine shops use only traditional machine tools and yet they make accurate machine parts and injection molds, taking of course, lots of time, effort and labor. Retrofitting technology is a highly common practice in developed countries, although it is interesting for us to dominate the retrofitting technology and to expand the knowledge in a low cost approach, because "it has a direct economical effect on production and in addition an indirect effect as it generates experiences in maintaining and handling of automated machines; this is of advantage for the companies executing the retrofitting by themselves." [Herbe,95]

Not only in Costa Rica are people interested in the low cost of retrofitting. There are very recent publications as mentioned [Herbe,95] and a set of publications by Professor Shih-Jer Huang and collaborators from the National Taiwan Institute of Technology [Shih,93], [Shih,93-1]

6. BIBLIOGRAPHY

- AM STAFF REPORT. At Emo, Europe Girds for Union, American Machinist, Vol. 135, No. 8, Agosto, 1991.
- COLEMAN, John, R. Take Control With CNC, Manufacturing Engineering, Vol. 104, No. 5, Mayo, 1990.
- D'AZZO, J.J., Houppis, C. H. Análise e Projeto de Sistemas de Controle. Segunda edição, Editora Guanabara, Rio de Janeiro, 1988.
- DA COSTA, Longuinho. Projeto de Máquinas-Ferramenta, apuntes de clase, Curso Diseño de Máquinas Herramienta, Departamento de Ingeniería Mecánica, Universidad Federal de Santa Catarina, Brasil, 1993
- Erbe, Heinz-H. Retrofitting Conventional Machine Tools to Numerical Control, 4 th Symposium Low Cost Automation, Buenos Aires, Argentina, September 1995, pp. 16-20
- ERICKSON, William, M. The Difference Between "Good Enough" and "Optimum" in Sizing Servomotors, REXROTH INDRAMAT, Ideas in Motion, Spring 1990.
- FUOCO, T. H., Furtado, M. R. Retrofitting. Esta é uma boa Opção, segundo quem já usou, Máquinas e Metais, Vol. 26, No. 309, Octubre, 1991.
- HOLLAND, Ted. Now IBAG's High Speeds Get even Higher Powers. Metalworking Production, Abril, 1989.
- KNUTTON, Peter. No Limit that can be Achieved..., Machinery and Production Engineering, Vol 147, No 3764, Julio, 1989.

- Kopacek, Peter. CIM for Small and Medium Sized Companies, 4 th Symposium Low Cost Automation, Buenos Aires, Argentina, September 1995, pp. 188-191
- LICHTBLAU, Marcos. Uma Contribuição ao Estudo da Dinâmica de Posicionadores. Dissertação de Mestrado, Universidad Federal de Santa Catarina, Brasil, 1989.
- MARTIN, Merrill, How to Select a Variable-Speed Drive, Machine Design, octubre 1990.
- OGATA, Katsuhiko. Dinámica de Sistemas. Prentice Hall, México, 1987.
- RAPSO, Luis A., Modernização e Análise Dinâmica de uma Máquina Ferramenta NC, Dissertação de Mestrado, Universidad Federal de Santa Catarina, Brasil, 1994.
- RAPSO, Luis A.; "Circuitos Integrados Controladores de Movimiento". Revista del Colegio Federado de Ingenieros y de Arquitectos. Abril/mayo 1995.
- SHIU-JER, H.; CHENG-FA, L, Servo-Drive Systems for Milling Machine Retrofit Application, International Journal of Machine Tools Manufacturing, vol. 33 No. 3 pp. 449-463, 1993.
- SHIU-JER, H.; MU-TYAN, Y, Theoretical and Experimental Study of PI Control, Adaptive Control and Variable Structure Control for Converted Traditional Milling Machines, International Journal of Machine Tools Manufacturing, vol. 33 No. 5 pp. 695-712, 1993.
- THK Co., LTD. Linear Motion System, Catalogo No. 75EA, y No. 100-1AE, Tokyo.